

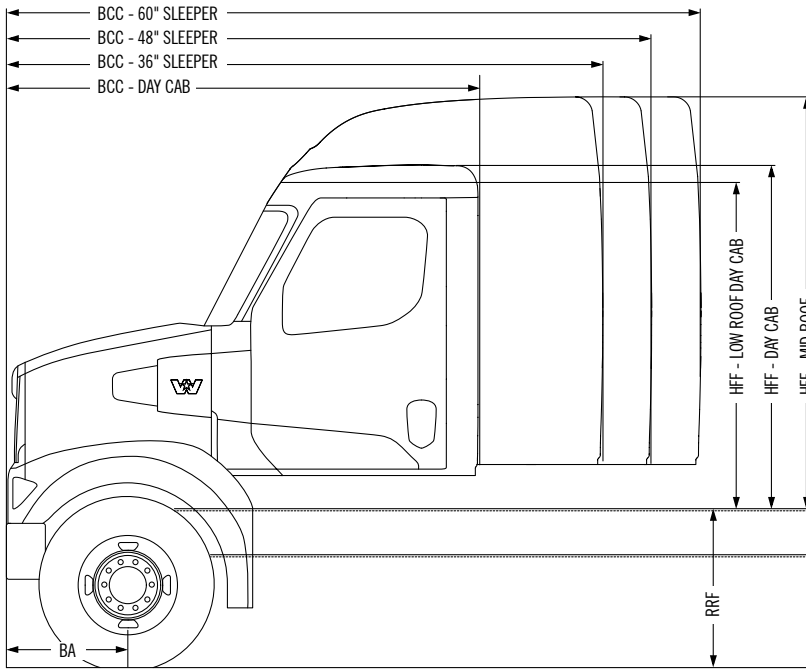

# WESTERN STAR 48X 6X4



### CONFIGURATIONS

STANDARD | 6 X 4 SINGLE STEER

### GCM

UP TO 130 TONNE GCM\*

\*HIGHER GCM RATINGS AVAILABLE  
SUBJECT TO APPLICATION AND  
ENGINEERING APPROVAL.

DESCRIPTION	MM
<b>BA - BUMPER TO AXLE</b>	
Bumper to axle	765
<b>BBC - BUMPER TO BACK OF CAB</b>	
Day cab	2,865
36" sleeper	3,565
48" sleeper	3,865
60" sleeper	4,165
<b>RRF - REAR FRAME HEIGHT - UNLADEN</b>	
Airliner	1,056
TuffTrac	1,084
Primax	1,072
Neway	1,072
<b>HFF - HEIGHT FROM FRAME</b>	
Day cab standard roof	2,042
Day cab low trench style roof	2,003
36" low trench style roof	2,012
36", 48" & 60" mid style roof	2,460
Mid roof style sleeper air kit	625

### > CAB

STD	Steel reinforced day cab w/- aluminium roof 2,865 mm/112.8" BBC
OPT	Low trench style roof steel reinforced day cab w/- composite roof
OPT	<b>SLEEPERS</b> 36" low trench style roof 36" mid style roof 48" mid style roof 60" mid style roof Additional roof fairing and side fairings - aerodynamic devices available

### > AIR INTAKE

STD	Side of bonnet air intake with engine mounted high capacity air cleaner and passive pre-cleaner
OPT	Dual air intake through hood mounted snorkles with RAM scoops, engine mounted high capacity air cleaner and dual passive pre-cleaners

### > ENGINE

STD	Detroit DD13 Gen 5 450 hp, 1,550 lb-ft
OPT	Detroit DD13 Gen 5 470-525 hp, 1,650-1,850 lb-ft Detroit DD16 GHG21 500-600 hp, 1,850-2,050 lb-ft

### > EXHAUST

STD	Horizontal ATS with LH B-pillar mounted vertical tailpipe
OPT	Horizontal ATS with right hand horizontal tailpipe Horizontal ATS with dual cab mounted vertical tailpipes Horizontal ATS with dual frame mounted vertical tailpipes

### > TRANSMISSION - AUTOMATED MANUAL

STD	Detroit DT12 OV 12 speed overdrive 1,550 lb-ft
OPT	Detroit DT12 OV 12 speed overdrive 1,650 lb-ft to 1,850 lb-ft Detroit DT12 OVX 12 speed overdrive 1,850 lb-ft to 2,050 lb-ft

### > TRANSMISSION - MANUAL

OPT	Eaton RTLO-16918B 1,650 lb-ft Eaton RTLO-18918B 1,850 lb-ft Eaton RTLO-20918B 2,050 lb-ft Eaton RTLO-22918B 2,250 lb-ft
-----	--

### > FRONT AXLE

STD	Meritor 6.6 t FG941 3.5" drop single front axle
OPT	Detroit 7.3 t DA-F 3.5" drop single front axle

### > FRONT SUSPENSION

STD	Taper leaf springs 6.6 t capacity - FG941
OPT	Taper leaf springs 7.3 t capacity - Detroit DA-F

### > REAR AXLE

STD	Meritor MX-40-14XGP 18.1 t GAWR tandem
OPT	Meritor MX44-14XGP 19.9 t GAWR tandem Meritor RT46-160GP 20.1 t GAWR tandem Meritor RT50-160GP 22.7 t GAWR tandem Meritor RT52-185G 23.6 t GAWR tandem Dana D46-172P 20.1 GAWR tandem

> **REAR SUSPENSION**

STD	Airliner 20.9 t GAWR air bag tandem
OPT	Airliner 18.1 t GAWR air bag tandem TufTrac Gen 2 18.1 t - 23.5 t GAWR mechanical tandem TufTrac Gen 2 Comfort Ride 18.1 t - 20.9 t GAWR mechanical tandem Hendrickson Primax EX 20.9 t GAWR air bag tandem Neway ADZ-252 23.5 t GAWR air bag tandem Neway AD-260 27.2 t GAWR air bag tandem

> **BRAKES**

STD	Bendix disc
OPT	Meritor drum

> **UPFIT EFFICIENCY SYSTEMS**

STD	Advanced multiplexed electrical system for easy truck equipment interface: <ul style="list-style-type: none"> <li>• Hard wired dash mounted auxiliary switches</li> </ul>
OPT	Manufacturer body builder interface, programming and power access Auxiliary in-cab or sleeper mounted e-vault available, which houses: <ul style="list-style-type: none"> <li>• QuickFit programmable controllers</li> <li>• QuickFit interface connectors</li> <li>• TEM-specific power distribution module</li> <li>• High-current power access</li> </ul>

> **WHEELS**

STD	Aluminium disc 10 stud
OPT	Steel disc 10 stud Standard, polished or Dura-Bright wheel finish available on Aluminium wheels

> **FUEL/HYDRAULIC & COMBINATION TANKS**

STD	Round 635 mm diameter 227 L to 567 L* Square (LCS) 735 mm x 700 mm 320 L to 775 L *Various fuel and hydraulic tank combinations available
-----	---



No matter where you are, we can get you going – 24 hour road assistance.

**0800 247 225**

> **SAFETY SYSTEMS**

STD	With Detroit DT12 transmissions: Detroit Assurance® Safety Systems including: <ul style="list-style-type: none"> <li>• Active Brake Assist 5</li> <li>• Adaptive cruise control to 0 kms with adj headway</li> <li>• Side guard assist (OPT)</li> <li>• Lane departure warning</li> <li>• Automatic wipers/headlamps</li> <li>• Intelligent high beam control</li> <li>• Brake hold</li> <li>• Electronic stability control</li> <li>• Anti-lock braking system</li> <li>• Detroit Connect and Virtual Technician platform hardware</li> <li>• Detroit Connect Safety Event Viewer package</li> <li>• Pre-Trip Inspection feature for exterior lamps</li> <li>• Alarm for door open, park brake not set</li> </ul>
OPT	With manual transmissions all of the above except: <ul style="list-style-type: none"> <li>• Standard (adaptive) cruise control</li> <li>• No brake hold</li> <li>• Optional lane departure warning</li> <li>• Optional side guard assist</li> </ul>

> **DRIVER INFORMATION MODULE**

STD	Premium instrument cluster with 125 mm TFT colour display
OPT	Digital dash displays with 300 mm centre panel cluster and 250 mm B-panel infotainment display

> **DRIVERS SEATS**

STD	ISRI high back air suspension seat with integrated 3 point seat belt
OPT	Rolltek Gen 2 air bag integrated into std ISRI seat ISRI Premium 2.0 high back air suspension seat with swivel base and non-integrated seat belts

> **PASSENGER SEATS**

STD	Sears tool box high back non suspension seat
OPT	ISRI high back air suspension seat with integrated 3 point seat belt ISRI Premium 2.0 high back air suspension seat with swivel base and non-integrated seat belts Battery box mid back non suspension seat

> **PAINT**

STD	Single colour cab and single colour chassis Cab - one colour basecoat/clearcoat, Chassis - one colour basecoat/clearcoat
OPT	Up to 4 colours. Base coat/Clearcoat solid colour, metallic or pearl