

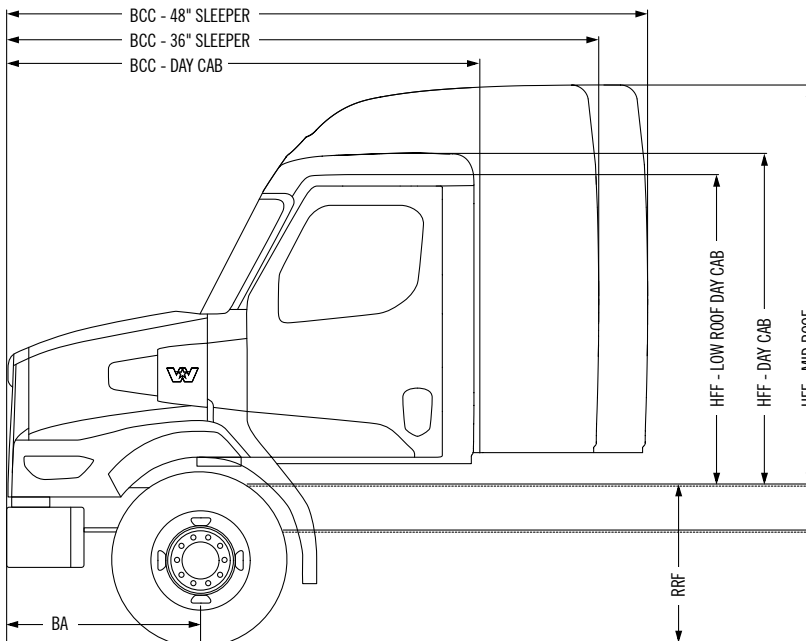

WESTERN STAR 47X



CONFIGURATIONS

STANDARD	6 X 4 SINGLE STEER
----------	--------------------

GCM

UP TO 72.5 TONNE GCM

DESCRIPTION

BA - BUMPER TO AXLE

Bumper to axle	1,180
----------------	-------

BBC - BUMPER TO BACK OF CAB

Day cab	2,835
36" sleeper	3,535
48" sleeper	3,835

RRF - REAR FRAME HEIGHT - UNLADEN

Airliner	1,056
TufTrac	1,084

HFF - HEIGHT FROM FRAME

Day cab standard roof	1,942
Day cab low trench style roof	1,903
36" low trench style roof	1,912
36" & 48" mid style roof	2,360
Mid roof style sleeper air kit	625

➤ **CAB**

STD	Steel reinforced day cab w/- aluminium roof 2,835 mm/111.6" BBC
OPT	Low trench style roof steel reinforced day cab w/ composite roof
OPT	SLEEPERS 36" low trench style roof 36" mid style roof 48" mid style roof Additional roof fairing and side fairings - aerodynamic devices available

➤ **AIR INTAKE**

STD	Single side of hood air intake with engine mounted high capacity air cleaner and passive precleaner
-----	---

➤ **ENGINE**

STD	Cummins L9 330 hp, 1,000 lb-ft
OPT	Cummins L9 350-380 hp, 1,050-1,250 lb-ft Detroit DD13 Gen 5 450-525 hp, 1,550-1,850 lb-ft

➤ **EXHAUST**

STD	Horizontal ATS with LH B-pillar mounted vertical tailpipe
OPT	Horizontal ATS with dual cab mounted vertical tailpipes

➤ **TRANSMISSION - AUTOMATED MANUAL**

OPT	Detroit DT12 OV 12 speed overdrive 1,550 lb-ft Detroit DT12 OV 12 speed overdrive 1,650-1,850 lb-ft
-----	--

➤ **TRANSMISSION - AUTOMATIC**

STD	Allison 3000 and RDS Series with PTO provision
OPT	Allison 3500 and RDS Series with PTO provision

➤ **TRANSMISSION - MANUAL**

OPT	Eaton RTLO-18918B 1,850 lb-ft Eaton RTLO- 20918B 2,050 lb-ft
-----	---

➤ **FRONT AXLE**

STD	Meritor 6.6 t FG941 3.5" drop single front axle
OPT	Detroit 7.3 t DA-F 3.5" drop single front axle

➤ **FRONT SUSPENSION**

STD	Taper leaf springs 6.6 t capacity - FG941
OPT	Taper leaf springs 7.3 t capacity - Detroit DA-F

➤ **REAR AXLE**

STD	Meritor MT44-14XGP 20 t GAWR tandem
OPT	Meritor MT-40-14XGP 18.1 t GAWR tandem Meritor RT46-160GP 20.9 t GAWR tandem

➤ **REAR SUSPENSION**

STD	Airliner 20.9 t GAWR air bag tandem suspension
OPT	Airliner 18.1 t GAWR air bag tandem suspension TufTrac Gen 2 18.1 t - 20.9 t GAWR mechanical tandem suspension TufTrac Gen 2 Comfort Ride 18.1 t - 20.9 t GAWR mechanical tandem suspension

> **BRAKES**

STD	Bendix disc
OPT	Meritor drum

> **UPFIT EFFICIENCY SYSTEMS**

STD	Advanced multiplexed electrical system for easy truck equipment interface: <ul style="list-style-type: none"> • Hard wired dash mounted auxiliary switches
OPT	Manufacturer body builder interface, programming and power access Auxiliary in-cab or sleeper mounted e-vault available, which houses: <ul style="list-style-type: none"> • QuickFit programmable controllers • QuickFit interface connectors • TEM-specific power distribution module • High-current power access

> **SAFETY SYSTEMS**

STD	With Cummins L9 and Eaton or Allison transmissions: Detroit Assurance® Safety Systems including: <ul style="list-style-type: none"> • Active Brake Assist 5 • Lane departure warning • Side guard assist (OPT) • Automatic wipers/headlamps • Intelligent high beam control • Standard cruise control • Electronic stability control • Anti-lock braking system • Detroit Connect and Virtual Technician platform hardware • Detroit Connect Safety Event Viewer package • Pre-Trip Inspection feature for exterior lamps • Alarm for door open, park brake not set
OPT	Additional features to above with Detroit DD13 engines and DT-12 transmissions <ul style="list-style-type: none"> • Adaptive cruise control to 0 kms • Brake hold <p>Note: Some safety items may differ or be not available with Cummins L9 engine or Allison/Eaton transmissions</p>

> **DRIVER INFORMATION MODULE**

STD	Premium instrument cluster with 125 mm TFT colour display
OPT	Digital dash displays with 300 mm centre panel cluster and 250 mm B-panel infotainment display

> **DRIVERS SEATS**

STD	ISRI high back air suspension seat with integrated 3 point seat belt
OPT	Rolltek Gen 2 air bag integrated into std ISRI seat ISRI Premium 2.0 high back air suspension seat with swivel base and non-integrated seat belts

> **PASSENGER SEATS**

STD	Sears tool box high back non suspension seat
OPT	ISRI high back air suspension seat with integrated 3 point seat belt ISRI Premium 2.0 high back air suspension seat with swivel base and non-integrated seat belts Battery box mid back non suspension seat

> **WHEELS**

STD	Aluminium disc 10 stud
OPT	Steel disc 10 stud Polished or Dura-Bright wheel finish

> **FUEL/HYDRAULIC & COMBINATION TANKS**

STD	Round 635 mm diameter 227 L to 567 L*
OPT	Square (LCS) 735 mm x 700 mm 320 L to 535 L *Various fuel and hydraulic tank combinations available

> **PAINT**

STD	Single colour cab. Cab - one colour basecoat/clearcoat, Chassis - one colour basecoat/clearcoat
OPT	Up to 4 colours. Base coat/Clearcoat solid colour, metallic or pearl



No matter where you are, we can get you going – 24 hour road assistance.

0800 247 225